

CATHOLIC HIGH SCHOOL
MID-YEAR EXAMINATION (2021)
PRIMARY SIX
SCIENCE
BOOKLET A

Name: _____ ()

Class: Primary 6 - _____

Date: 11 May 2021

28 questions

56 marks

Total Time for Booklets A and B: 1 hour 45 minutes

INSTRUCTIONS TO CANDIDATES

Do not turn over this page until you are told to do so.

Follow all instructions carefully.

Answer all questions.

Shade your answers in the Optical Answer Sheet (OAS) provided.

This booklet consists of 20 printed pages, excluding the cover page.

Booklet A (28 × 2 marks)

For each question from 1 to 28, four options are given. One of them is the correct answer. Make your choice (1, 2, 3 or 4). Shade your answer on the Optical Answer Sheet. (56 marks)

1 Which conditions have to be present for bread to turn mouldy?

- A light
- B water
- C oxygen
- D carbon dioxide

- (1) A and C only
- (2) A and D only
- (3) B and C only
- (4) B and D only

2 The diagram below shows the human digestive system.

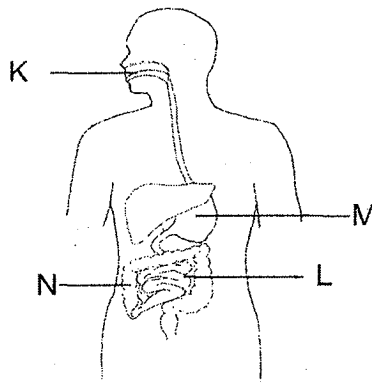

Which of the following is correct?

	Organ involved in digestion of food	Organ involved in absorption of food
(1)	K	M
(2)	L	K
(3)	M	L
(4)	N	N

3 The diagram below shows the life cycle of a mosquito.

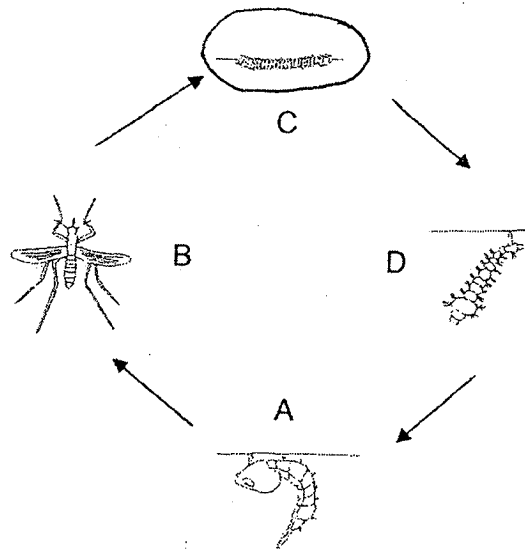

Tim sprayed oil on the possible breeding grounds of mosquitoes in order to reduce the number of mosquitoes.

Which stages will be most affected by this method?

- (1) A and B
- (2) A and D
- (3) B and C
- (4) A, C and D

- 4 The diagram below shows tree P near the foot of a hill.

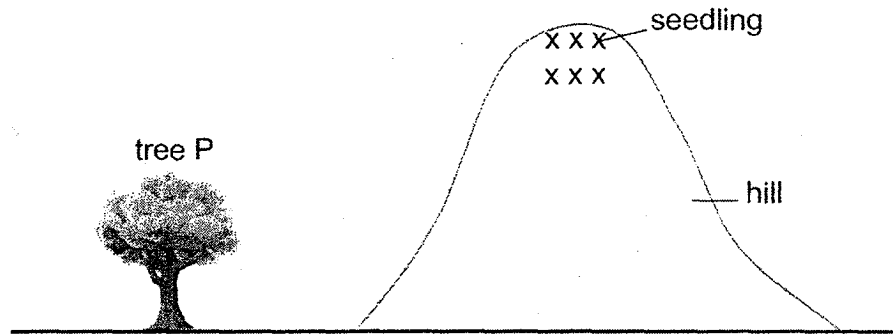

After some time, seedlings of tree P were found growing on the hill as shown in the diagram above.

Which are possible characteristics of the fruits of tree P?

- A dry pods
- B fibrous husks
- C fleshy edible parts
- D wing-like structures

- (1) A and C only
- (2) C and D only
- (3) A, B and D only
- (4) B, C and D only

- 5 The diagram below shows the processes that a flower undergoes to become parts P and Q.

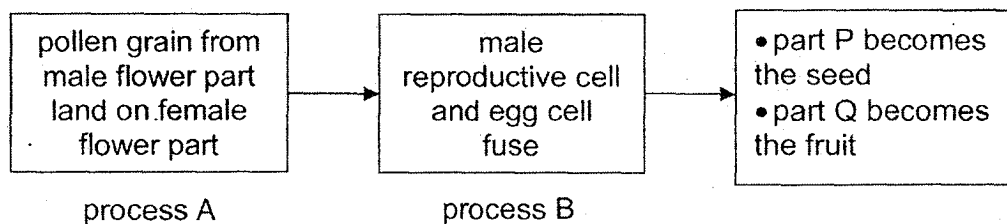

Which of the following correctly represents A, B, P and Q?

	Process A	Process B	Part P	Part Q
(1)	pollination	fertilisation	ovule	ovary
(2)	fertilisation	pollination	ovule	ovary
(3)	germination	dispersal	ovary	ovule
(4)	pollination	germination	ovary	ovule

6 Which statements are correct about the sexual reproduction of humans?

- A The male reproductive cell is the sperm.
- B The fertilised egg develops in the stomach of the female's body.
- C Fertilisation usually takes place in the ovary of the female's body.
- D Fertilisation takes place when the male and female reproductive cells fuse.

- (1) A and D only
- (2) B and C only
- (3) C and D only
- (4) A, B and C only

7 The diagram below shows how water and food are transported in plants. J, K and L represent different plant parts.

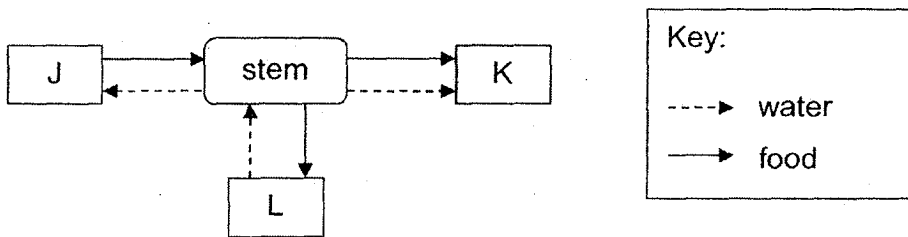

Which of the following correctly represents J, K and L?

	J	K	L
(1)	fruits	leaves	roots
(2)	leaves	roots	fruits
(3)	roots	fruits	leaves
(4)	leaves	fruits	roots

- 8 The diagram below shows the human circulatory system. A, B and C are organs while the arrows are blood vessels.

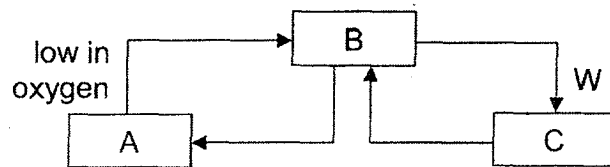

Which of the following correctly represents A, B, C and W?

	A	B	C	W
(1)	stomach	heart	lungs	low in oxygen
(2)	lungs	heart	stomach	high in oxygen
(3)	heart	lungs	stomach	low in oxygen
(4)	stomach	lungs	heart	high in oxygen

- 9 The diagram below shows three types of cells P, Q and R.

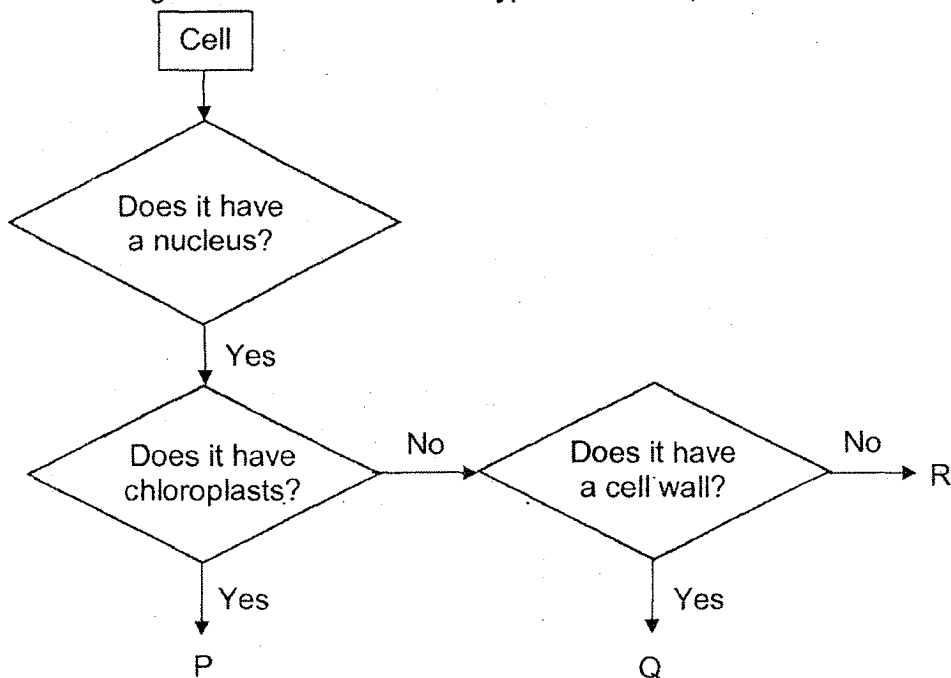

Which of the following correctly represents P, Q and R?

	P	Q	R
(1)	leaf cell	root cell	human skin cell
(2)	leaf cell	flower cell	stem cell
(3)	stem cell	human skin cell	root cell
(4)	stem cell	flower cell	root cell

10 Amy set up an experiment as shown below.

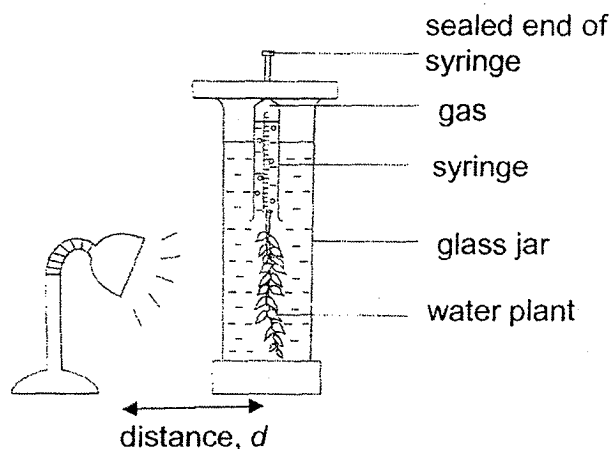

She counted the number of bubbles produced by the water plant per minute with varying distances between the water plant and lamp. The results were shown below.

Distance, d (cm)	Number of oxygen bubbles produced per minute
10	55
15	40
20	26
25	12

The above set-up without the lamp was then placed in an open field on a clear day.

Which conclusion can Amy infer from the above experiment?

- (1) Light intensity has no effect on the rate of photosynthesis.
- (2) The water plant can only photosynthesise in the presence of light.
- (3) The rate of photosynthesis increases as the light intensity increases.
- (4) The rate of photosynthesis increases as the light intensity decreases.

- 11 The diagram below shows a food web.

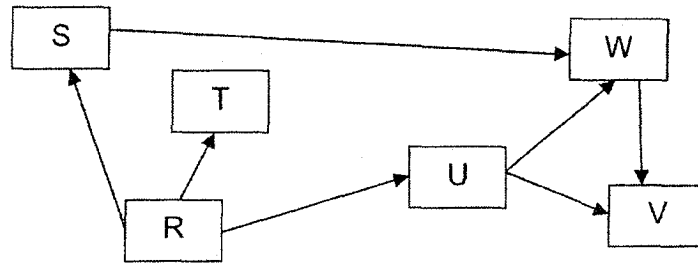

Jim made three statements about the food web.

- A T is a predator.
- B There is only one producer.
- C The energy in S is transferred to W.

Which statement(s) is/are correct?

- (1) A only
 - (2) B only
 - (3) B and C only
 - (4) A, B and C
- 12 The graph below shows the population of bees in a community over a period of time.

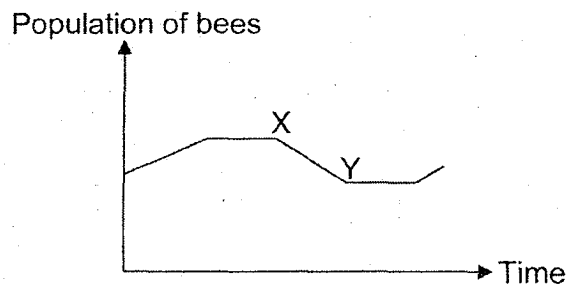

Which of the following explains the population of bees shown by XY in the graph?

- A There was a drought.
- B Butterflies were introduced to the habitat.
- C A disease had infected some flowering plants.
- D More land was used for the building of houses.

- (1) A and B only
- (2) B and C only
- (3) C and D only
- (4) A, B, C and D

13 The diagram below shows insects A and B.



insect A



insect B

Insects A and B look similar. Insect B can sting its predator but insect A cannot.

How does insect A benefit from looking like insect B?

- A It helps deter predators.
 - B It helps attract mates for reproduction.
 - C It helps insect A blend with the surroundings.
-
- (1) A only
 - (2) A and C only
 - (3) B and C only
 - (4) A, B and C

- 14 Ed observed the organisms found in a garden and recorded the number of each organism in a graph as shown below.

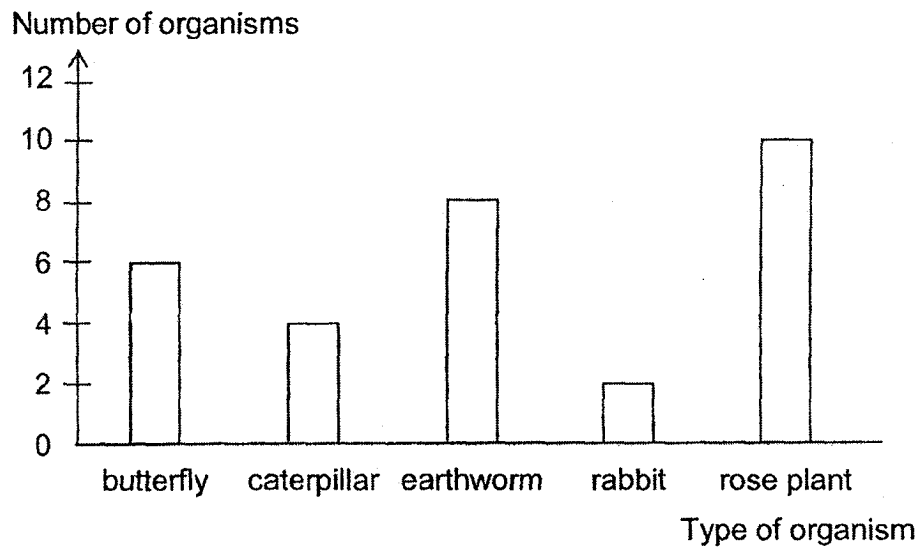

Based on the information above, which statements are definitely correct?

- A The garden is the habitat of each organism.
- B There are four populations living in the garden.
- C There is a total of 31 communities in the garden.
- D There are 10 populations of plants in the garden.

- (1) A and B only
- (2) A and D only
- (3) B and C only
- (4) C and D only

- 15 Serene placed three solids made of materials F, G and H into a tank of water as shown below.

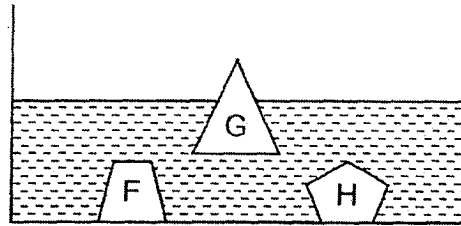

She made two statements.

- A F and H have the same mass.
B There is more gravitational force acting on H than G.

Which statement(s) can be concluded from her observation?

- (1) A only
(2) B only
(3) A and B
(4) None of the statements
- 16 Paul wants to transfer 60 cm^3 of oxygen from a gas tank into another cylinder.

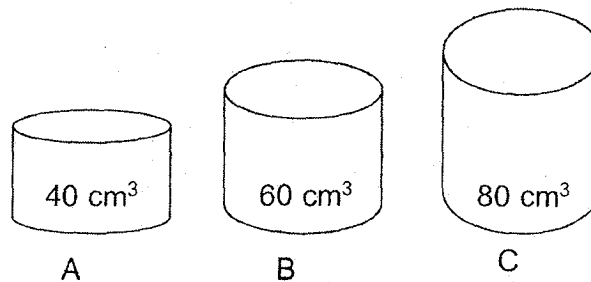

Which cylinder(s) can he use to hold the oxygen?

- (1) A only
(2) C only
(3) A and B only
(4) A, B and C

- 17 The diagram below shows three bar magnets J, K and L when they are placed near one another. The poles of magnet J are as shown.

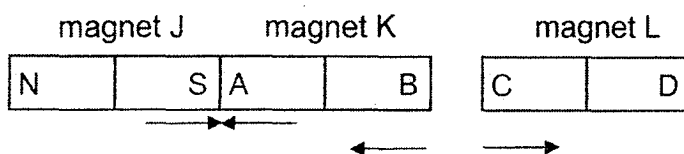

Magnet K and a non-magnetic ball are placed near the edge of a table as shown below.

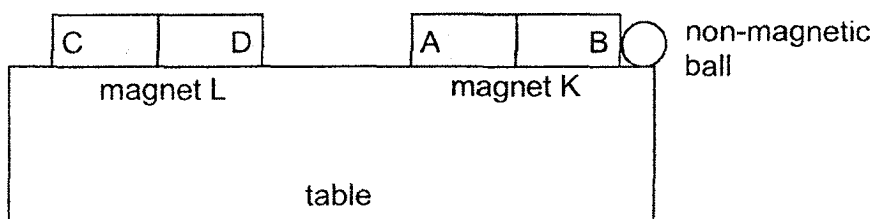

Which of the following explains what would happen to the non-magnetic ball?

	Cause	Effect
(1)	Magnetic force of repulsion	Non-magnetic ball did not move.
(2)	Magnetic force of attraction	Did not affect the non-magnetic ball.
(3)	Magnetic force of repulsion	Non-magnetic ball rolled off the table.
(4)	Magnetic force of attraction	Non-magnetic ball rolled off the table.

- 18 Three similar cubes X, Y and Z were placed in a straight line and light was shone on them. The diagram below shows the top view of the positions of cubes X, Y and Z which were placed between the light source and the screen on a table top.

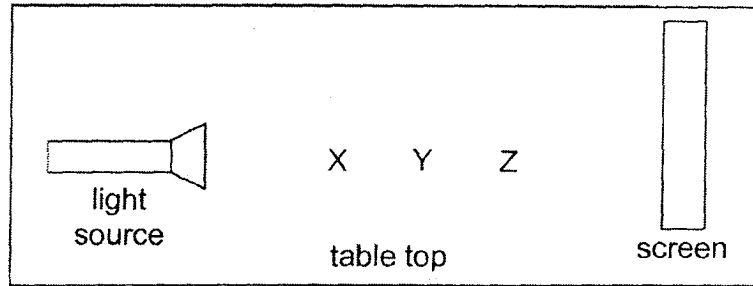

The shadow formed on the screen is shown in the diagram below.

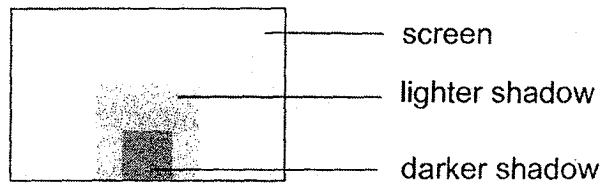

Which of the following best represents the amount of light passing through cubes X, Y and Z?

(1)

Cubes	Amount of light passing through		
	none	some	most
X	✓		
Y			✓
Z		✓	

(2)

Cubes	Amount of light passing through		
	none	some	most
X	✓		
Y		✓	
Z			✓

(3)

Cubes	Amount of light passing through		
	none	some	most
X			✓
Y	✓		
Z		✓	

(4)

Cubes	Amount of light passing through		
	none	some	most
X			✓
Y		✓	
Z	✓		

- 19 The graph below shows how the temperature of two beakers of water X and Y changes over time. Both beakers are made of the same material.

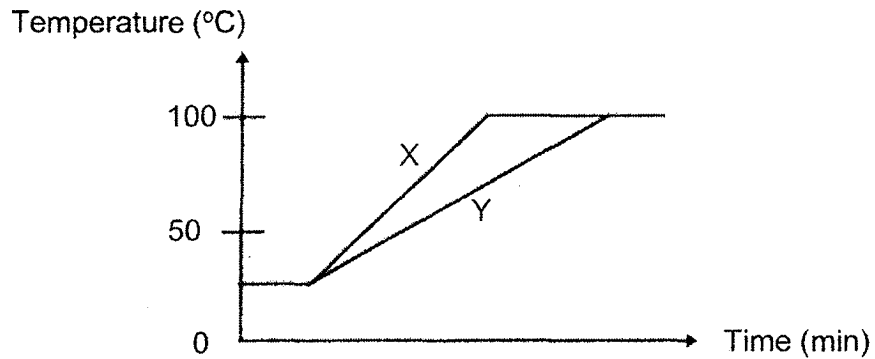

Which statement describes the graph correctly?

- (1) Both beakers of water boil at the same time.
 - (2) Beaker X contains less water than Beaker Y.
 - (3) Beaker X is a poorer conductor of heat than Beaker Y.
 - (4) Beaker Y is heated over a stronger flame than Beaker X.
- 20 Kenan wanted to find out the effect of wind speed on the rate of evaporation of water. He prepared four set-ups using containers made of the same material under different conditions.

Set-up	Exposed surface area (cm ²)	Volume of water (ml)	Surrounding temperature (°C)	Wind speed (km/h)
A	40	80	26	12
B	50	80	29	16
C	50	80	29	18
D	60	80	26	16

Which set-ups should he use for his experiment?

- (1) A and B
- (2) A and D
- (3) B and C
- (4) C and D

- 21 Two plastic containers A and B containing the same amount of water are balanced as shown.

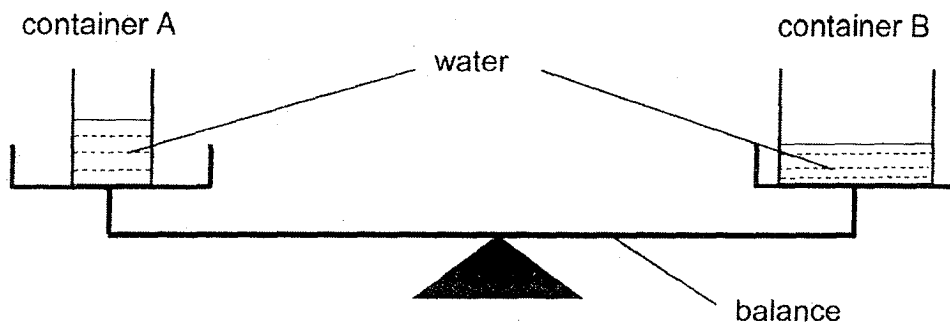

The set-up was left in an open space on a sunny day for a few hours.

Which of the following shows the correct observation and explanation for the experiment after a few hours?

	Observation	Explanation
(1)	The side with container A would tilt downwards.	The water level in container A was higher than that in container B.
(2)	The side with container A would tilt downwards.	There would be less water in container B due to more evaporation of water from container B.
(3)	The side with container B would tilt downwards.	There would be less water in container A due to more evaporation of water from container A.
(4)	Containers A and B would still balance each other.	The containers were of the same mass and both contained the same amount of water.

- 22 Study circuits A, B, C and D as shown below. The bulbs and the batteries in the four circuits are identical. All the bulbs are lit up.

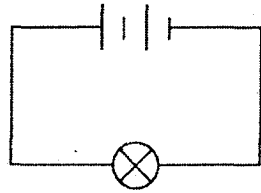

circuit A

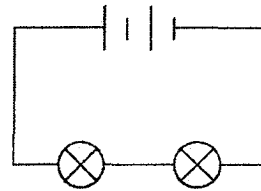

circuit B

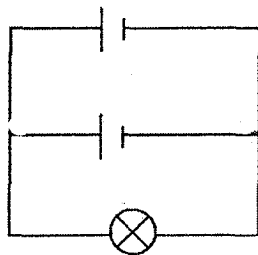

circuit C

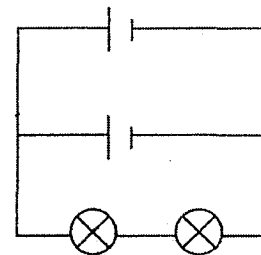

circuit D

Which statement about the brightness of the bulbs is correct?

- (1) The bulb in circuit A is as bright as the bulb in circuit C.
- (2) The bulb in circuit A is as bright as each bulb in circuit D.
- (3) Each bulb in circuit B is brighter than the bulb in circuit C.
- (4) Each bulb in circuit B is brighter than each bulb in circuit D.

- 23 Susan carried out an experiment to find out if materials X, Y and Z allow electricity to pass through. She connected materials X, Y and Z to the circuit at positions 1, 2 and 3 respectively as shown below.

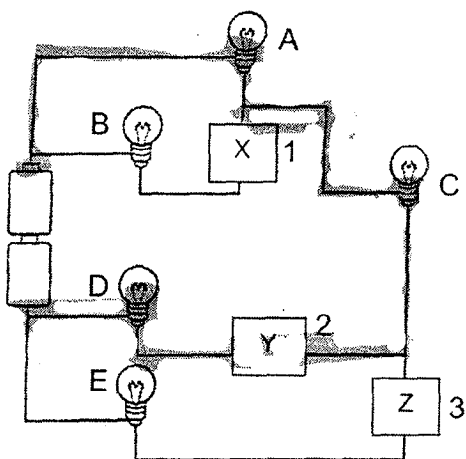

She observed that only bulbs A, C and D lit up. She then swapped the materials to different positions and recorded her observations.

Which of the following is correct?

	Position 1	Position 2	Position 3	Bulbs lit up
(1)	Y	X	Z	A and B
(2)	Y	Z	X	A, B and C
(3)	Z	X	Y	A, C and E
(4)	X	Z	Y	B, C and D

- 24 Ying Ning threw a ball from point W. The diagram below shows the position of the ball at points X, Y and Z after it was thrown.

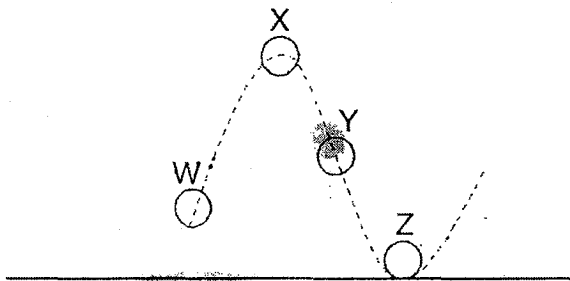

She described the energy the ball possessed when it was at points W, X, Y and Z.

Which statements are correct?

- A There is no potential energy at point W.
- B The kinetic energy at point Y is higher than the kinetic energy at point Z.
- C The potential energy at point X is higher than the potential energy at point Z.
- D The kinetic energy is decreasing as the ball travels from point W to point X.

- (1) A and B only
- (2) C and D only
- (3) A, C and D only
- (4) B, C and D only

- 25 Blocks A, B, C, X and Y are placed on a shelf as shown in the diagram below.

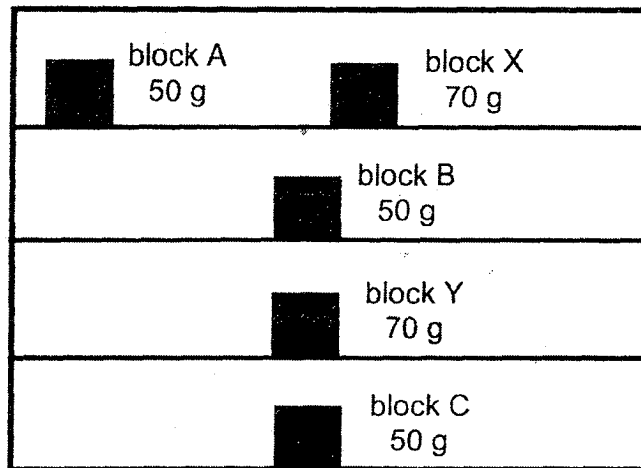

Which statements are correct?

- A Block A has more potential energy than block B.
- B Block A has more potential energy than block X.
- C When both blocks B and C fall off the shelf, block B will have more kinetic energy than block C.
- D When both blocks X and Y fall off the shelf, block X converts less potential energy to sound energy than block Y.

- (1) A and B only
- (2) A and C only
- (3) A, C and D only
- (4) B, C and D only

- 26 Alice released a ball from Point W as shown in the diagram below. The ball rolled down the slope, moved along the carpet flooring and stopped at point Z.

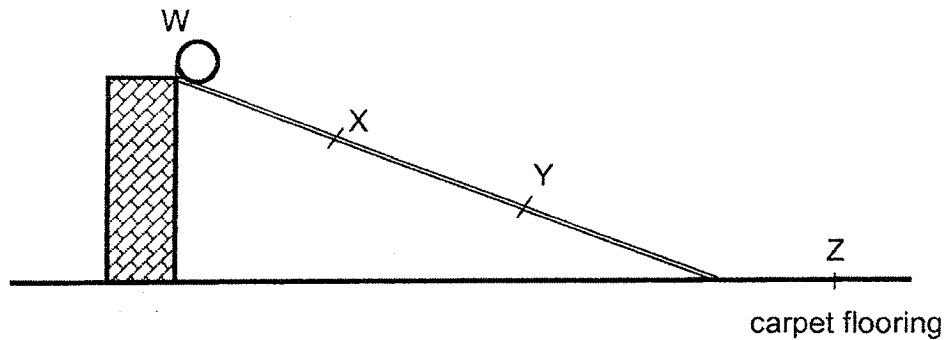

Which statements are correct?

- A At points X and Y, the ball had kinetic energy only.
- B The ball would have rolled down faster if the slope was shorter.
- C The ball had the greatest amount of gravitational force at point W.
- D The ball would have rolled further if the experiment was conducted on a smoother floor.

- (1) A and B only
- (2) B and D only
- (3) A, C and D only
- (4) B, C and D only

27 Which of the following is **not** an example of the effects of a force?

- (1) a child dropping a ball
- (2) a board stopping a dart
- (3) a pump inflating a balloon
- (4) a roof blocking the sunlight

28 Hinton made four round dough W, X, Y and Z of the same size. He then dropped each dough from different heights onto a table top. His observations were shown in the diagram below.

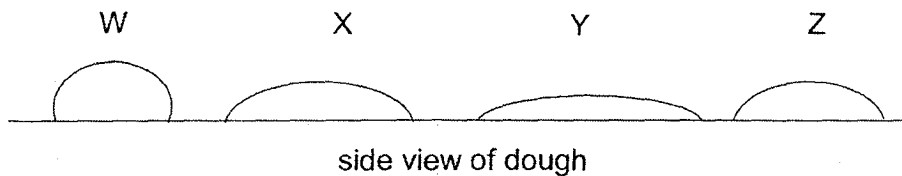

Which of the following shows the correct order the dough was dropped from the lowest height to the highest height?

	Lowest	→		Highest
(1)	W	Z	X	Y
(2)	W	X	Z	Y
(3)	X	Z	Y	W
(4)	Y	X	Z	W

End of Booklet A

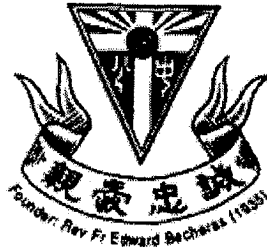

CATHOLIC HIGH SCHOOL
MID-YEAR EXAMINATION (2021)
PRIMARY SIX
SCIENCE
BOOKLET B

Name: _____ ()

Class: Primary 6 - _____

Date: 11 May 2021

Parent's Signature: _____

Booklet A	56
Booklet B	44
Total	100

13 questions

44 marks

Total Time for Booklets A and B: 1 hour 45 minutes

INSTRUCTIONS TO CANDIDATES

Do not turn over this page until you are told to do so.

Follow all instructions carefully.

Answer all questions.

Write your answers in this booklet.

This booklet consists of 15 printed pages, excluding the cover page.

Booklet B (44 marks)

For questions 29 to 41, write your answers in this booklet.

The number of marks available is shown in brackets [] at the end of each question or part question. (44 marks)

29 Aminah conducted an experiment with two fruits A and B as shown.

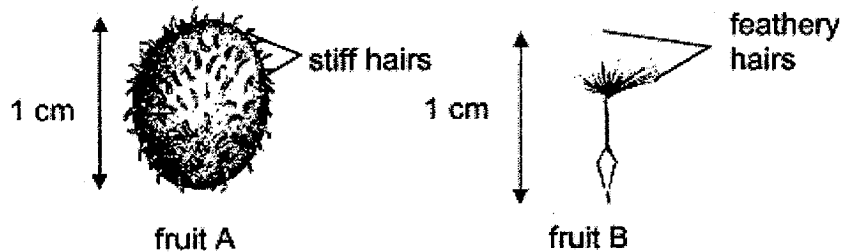

(a) State the method of dispersal for fruits A and B. [1]

Fruit A: _____ Fruit B: _____

She dropped fruits A and B from a height of 120 cm in front of a fan. She measured the distance, d , travelled by the fruits.

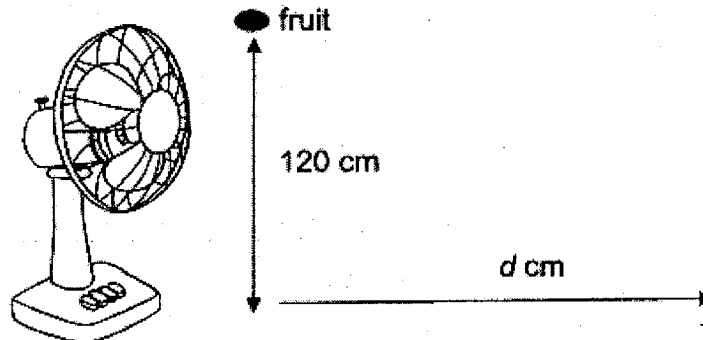

The results are shown below.

Fruit	A	B
Distance, d (cm)	5	50

(b) Explain how keeping the height at which the fruit was dropped the same ensures a fair test. [1]

(Go on to the next page)

SCORE	2
-------	---

- 30 An outer ring of a stem was removed from a plant as shown in the diagram below. As a result, the tubes carrying food were removed.

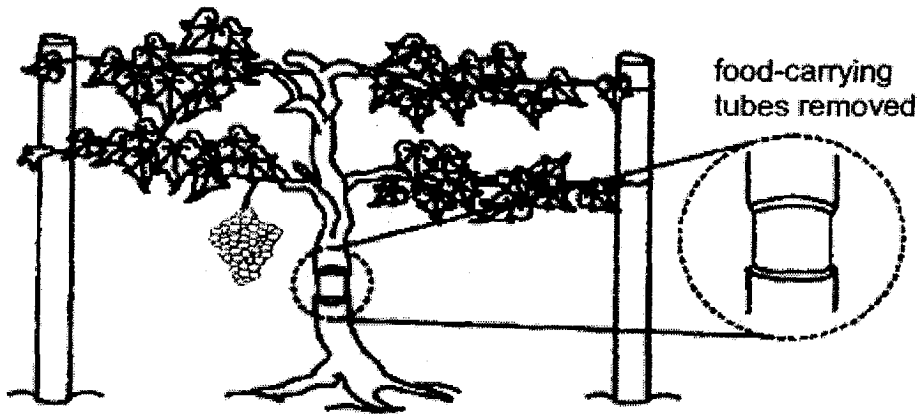

- (a) After some time, the plant produced fruits as shown above. It was observed that the plant produced bigger fruits compared to the fruits of a plant with uncut stem. Explain why bigger fruits were produced. [2]

- (b) After some time, it was observed that the plant died. Give a reason why removing the outer ring of the stem caused the plant to die. [1]

(Go on to the next page)

SCORE	3
-------	---

- 31 The flow of substances between different body systems in humans can be represented by the diagram below:

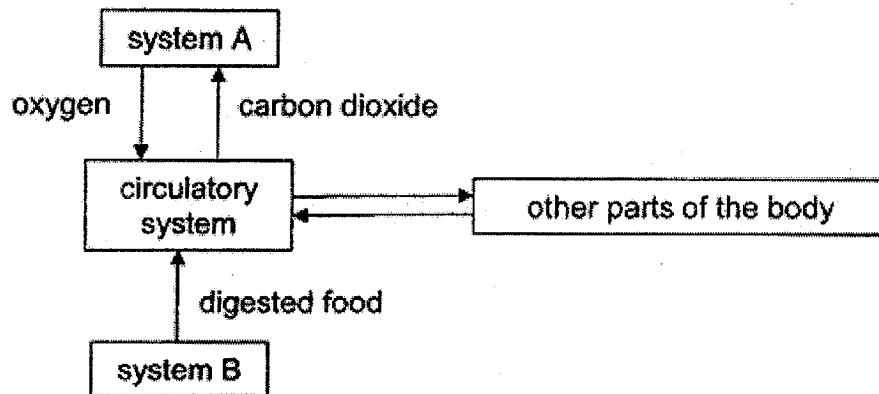

- (a) State systems A and B.

[1]

System A: _____ System B: _____

The diagram below shows the volume of blood passing through the small intestine during rest and exercise over a period of time.

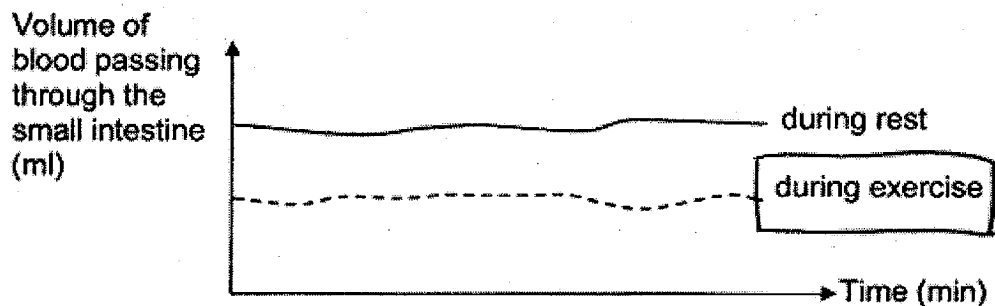

- (b) Based on the graph above, explain how exercising after a meal affects the absorption of digested food in the small intestine.

[2]

(Go on to the next page)

SCORE	3
-------	---

- 32 Maya had three tubes A, B and C. Each tube contains an equal amount of chloroplasts mixed in an equal amount of blue liquid X. This blue liquid would turn green after photosynthesis has taken place. Maya placed tube A at a distance of 10 cm from the lamp.

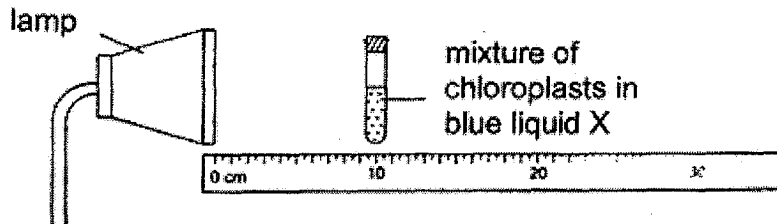

She switched on the lamp and recorded the time taken for the mixture to turn green. She repeated the experiment with tubes B and C at various distances from the lamp as shown in the table below.

Tubes	Distance from lamp (cm)	Time taken for mixture to turn green (s)
A	10	9
B	20	22
C	30	36

- (a) The time taken for the mixture to turn green increases as the distance from the lamp increases. Explain why. [1]

- (b) Maya conducted the experiment in a dark room. Give a reason why this helped to make the experiment a fair test. [1]

Maya repeated the experiment with a fourth tube Z. Z had a different amount of chloroplasts from tube A. He placed tube Z at a distance of 10 cm from the lamp. The time taken for the mixture to turn green was 5 seconds.

- (c) Which tube, A or Z, had a larger amount of chloroplasts? Explain your answer. [1]

(Go on to the next page)

SCORE	3
	3

- 33 Glenn conducted an experiment using the set-ups as shown. The two beakers were identical and contained the same amount of cold water at the same temperature.

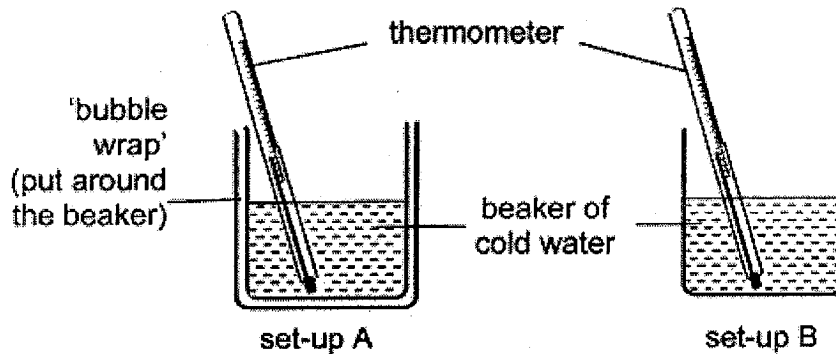

Glenn's results are shown below.

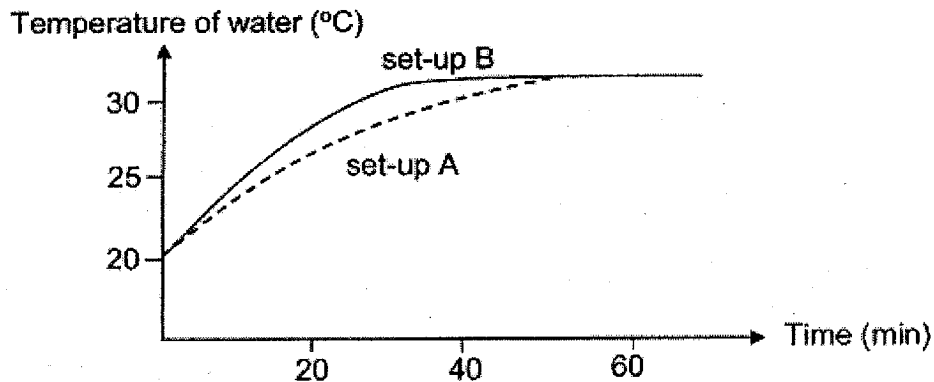

- (a) Based on Glenn's results, what can he conclude about the property of air? [1]

Bird X has a thick layer of feathers. There are air pockets among the feathers.

- (b) Based on the results of Glenn's experiment, explain how puffing up the feathers keeps Bird X warm during cold weather. [1]

(Go on to the next page)

SCORE	2
-------	---

Continue from Question 33

After bird X has migrated to a new habitat, it starts to build nests using brown twigs on the ground. It lays eggs that are light brown with darker brown spots.

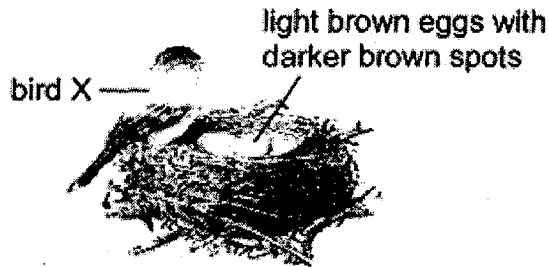

- (c) In winter, bird X migrates to warmer areas. Other than to avoid the low temperature, suggest a reason for the migration. [1]

- (d) Explain how the appearance of the eggs increases the chances of survival for bird X. [2]

(Go on to the next page)

SCORE	3
-------	---

- 34 Organism X is an animal eater which has many finger-like structures as shown in the diagram below. Organism Y contains chlorophyll like plants and it hides inside organism X.

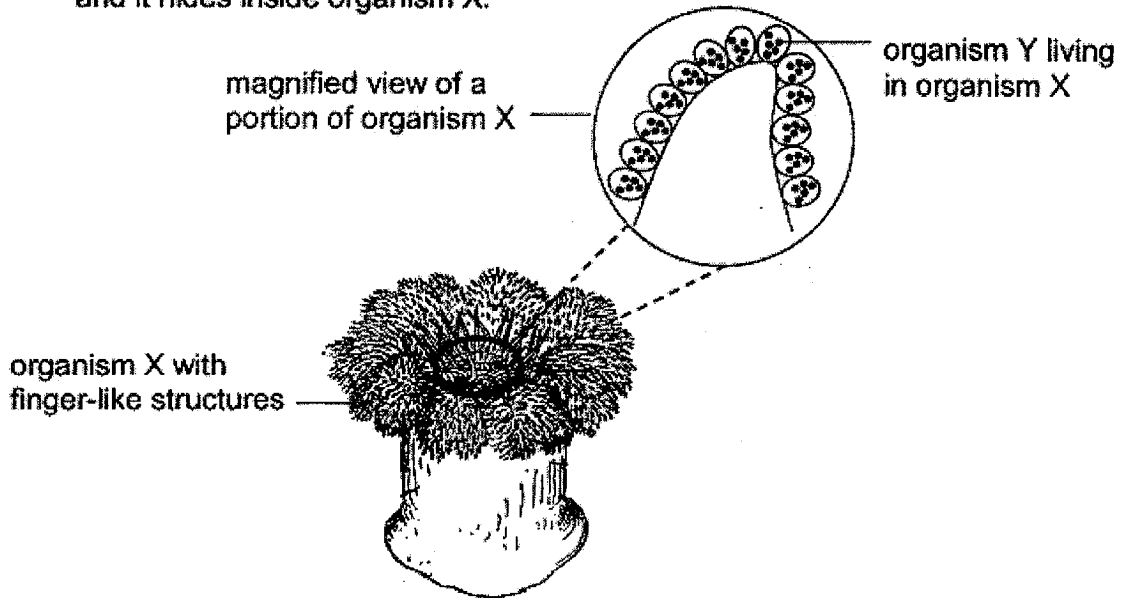

Both organisms depend on each other for survival.

- (a) State the type of adaptations, behavioural or structural, for the adaptations in the table below. [1]

Adaptations	Type of adaptations
Organism X has finger-like structures.	
Organism X feeds more actively at night.	

- (b) How do organism X and organism Y benefit from this relationship? [2]

Benefit for organism X:

Benefit for organism Y:

(Go on to the next page)

SCORE	3
-------	---

- 35 Justin used the stroking method to make a temporary magnet. He recorded some information in the table below.

Number of strokes applied to the iron nail	Number of paper clips attracted
20	2
40	4
60	8

- (a) What is the relationship between the number of strokes applied to the iron nail and the number of paper clips attracted? [1]

- (b) If Justin had used a copper nail rather than an iron nail, would he be able to observe any paper clips attracted to the copper nail? Why? [1]

After Justin had stroked his iron nail 100 times, he placed object W near to the iron nail. He observed that object W was attracted to the iron nail as shown in the diagram below.

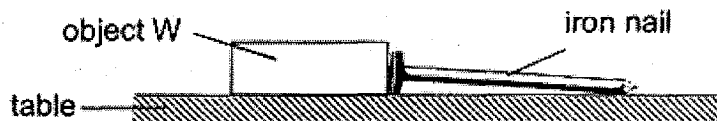

- (c) Justin concluded that object W was a magnet. Do you agree with him? Explain your answer. [1]

(Go on to the next page)

SCORE	3
-------	---

- 36 Leslie shone a torch on a wooden cylinder from two different positions as shown in the diagram below.

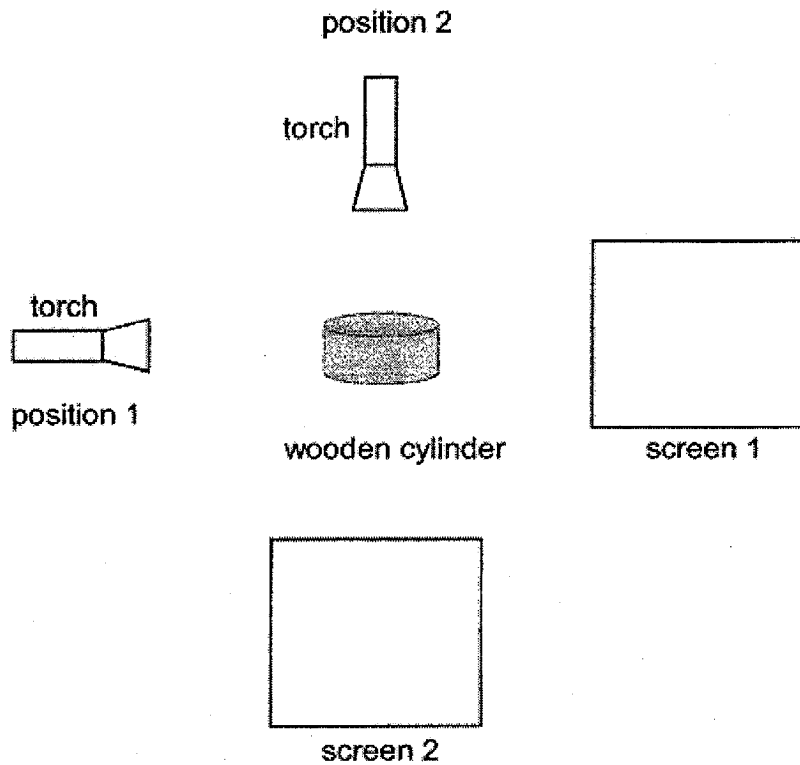

(a) Draw the shadows that would be formed on the two screens. [1]

(b) Explain how the shadow on screen 2 was formed. [1]

(c) What could Leslie do to the torch in position 2 if he wanted a smaller shadow to be formed on screen 2? [1]

(Go on to the next page)

SCORE	3
-------	---

- 37 Cups X and Y were made of different materials. Both cups were filled with the same amount of water at 10°C and left in a room. The room temperature was 30°C .

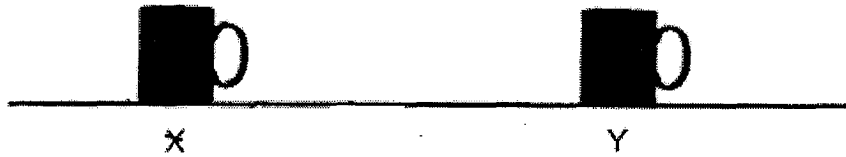

The temperature of water in both cups was measured every five minutes.

The table below shows the changes in the temperature of water in cup X over a period of 20 minutes.

Time (min)	0	5	10	15	20
Temperature of water ($^{\circ}\text{C}$)	10	14	18	22	26

- (a) Cup X felt colder than cup Y when touched. Would the temperature of the water in cup Y be equal to, higher or lower than 26°C at the 20th minute? Explain your answer. [2]

- (b) Which cup X or Y would keep warm drinks warmer for a longer period of time? Explain your answer. [1]

(Go on to the next page)

SCORE	3
-------	---

- 38 The diagram below shows how water can be obtained from sea water with a water cone.

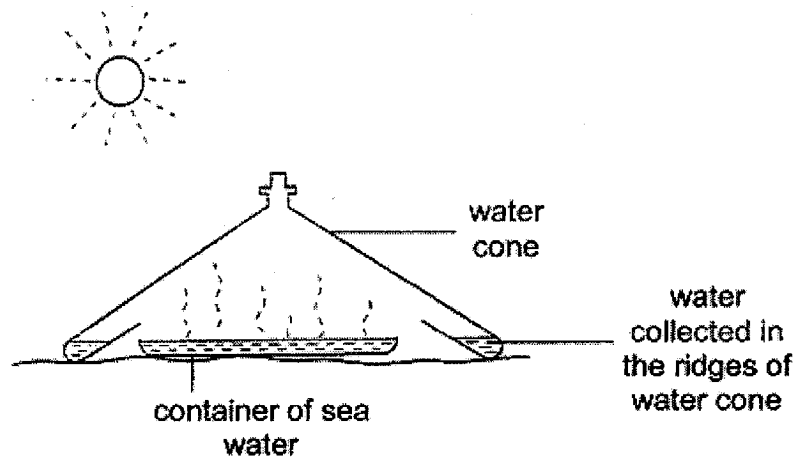

- (a) Using the diagram, describe how water was collected in the ridges of the water cone. [2]

- (b) The water collected in the ridges of the cone is unsafe for drinking immediately. Why? [1]

(Go on to the next page)

SCORE	3
-------	---

- 39 Drake used the set-up below to power up his LCD digital clock. A small current can be generated by the reaction of the zinc and copper in the presence of the lemon juice. The lemon functions like a battery.

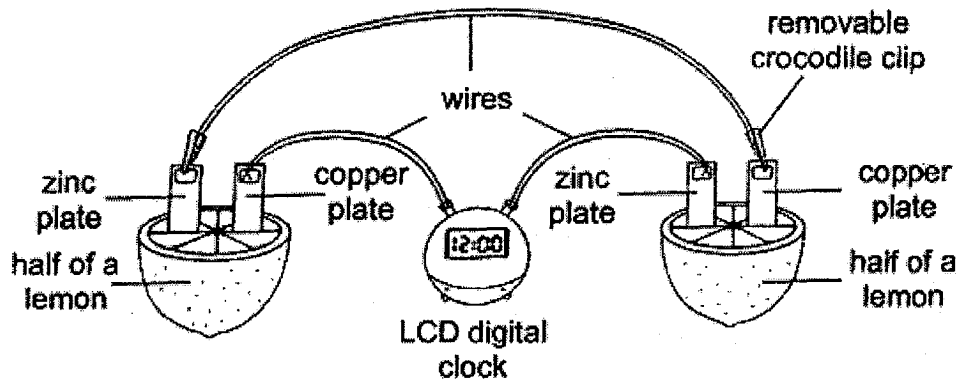

- (a) State a property of the zinc and copper plate that allowed the LCD digital clock to work. [1]

- (b) Fill in the boxes with the forms of energy to power up the LCD digital clock. [1]

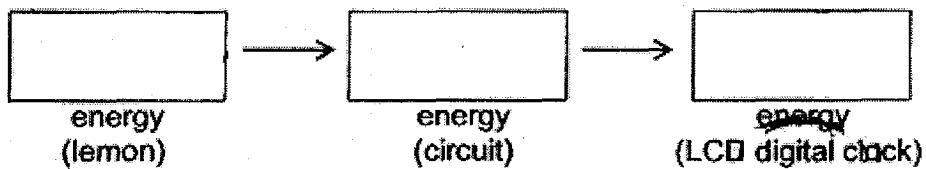

- (c) Explain what would happen to the LCD digital clock when Drake removed the crocodile clip from the copper plate. [2]

(Go on to the next page)

SCORE	4
-------	---

40 Zach used the set-up below to study four types of springs P, Q, R and S.

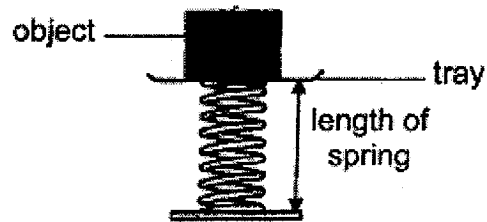

He placed objects of different mass on each spring and measured the length of the spring. The results were shown below.

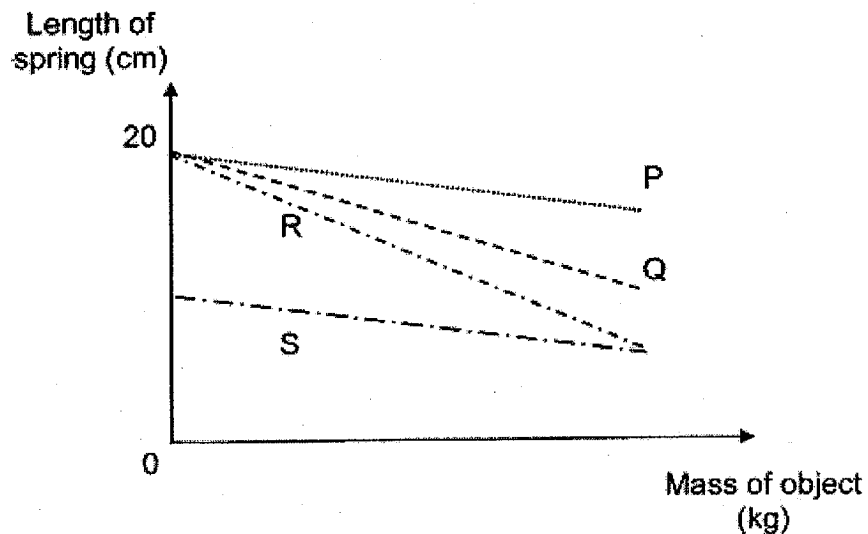

- (a) Name the force(s) that was/were acting on the spring when the object was placed on the tray. [1]

Using the same set-up, Zach wanted to compare the mass of two apples which had only a slight difference in mass. The mass of each apple was about 100 g.

- (b) Which spring P, Q, R or S was the most suitable when comparing the weight of the two apples? Give a reason for your answer. [2]

(Go on to the next page)

SCORE	3
-------	---

Continue from Question 40

Zach conducted another experiment using a different spring T. He hung a 5 g load on T and measured the increase in the length of T. He repeated the experiment by adding a 5 g load, one at a time, until the total load was 25 g.

Next Zach started to remove the 5 g load, one at a time, until all the loads were removed. The results were shown below.

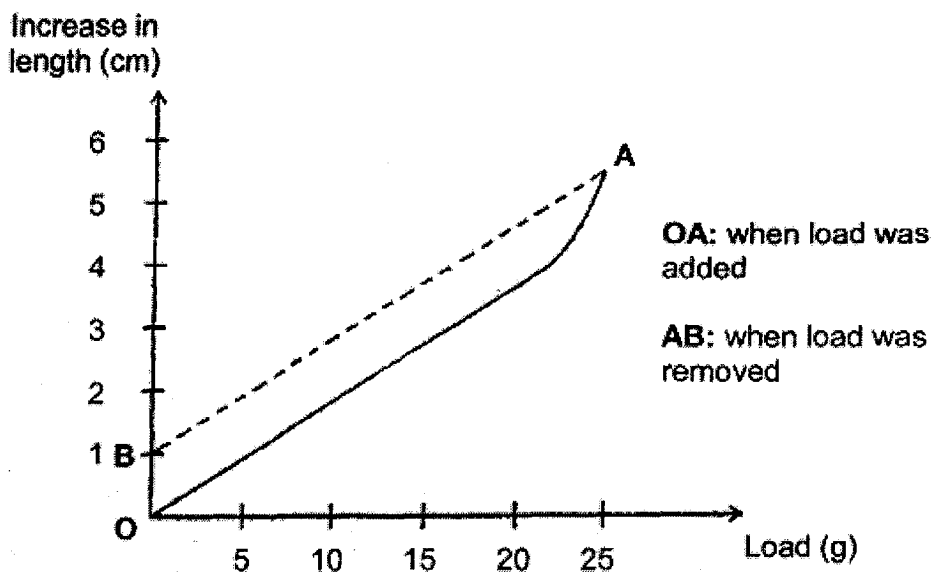

- (c) If the original length of the spring was 3 cm, what was its length when all the loads were removed? Explain your answer. [2]

(Go on to the next page)

SCORE	2
-------	---

- 41 The diagram below shows a track constructed by Keith and Frank. Keith released a marble from point A of the track while Frank released a similar marble from point Z of the track at the same time as Keith.

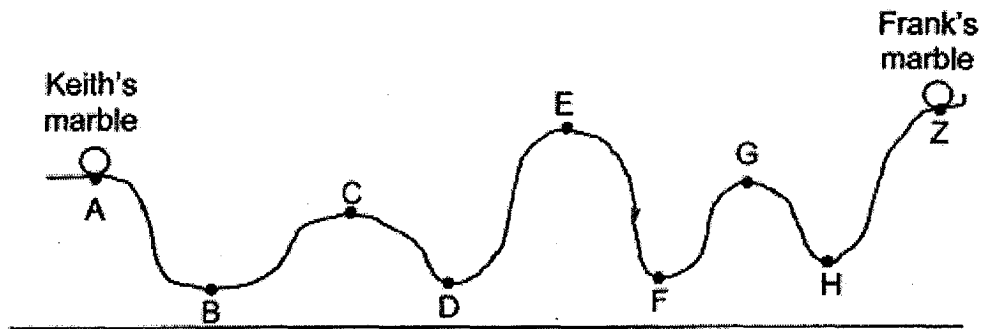

- (a) At the start of the experiment, whose marble had a greater amount of potential energy? Give a reason. [1]

- (b) Describe the change in energy in Frank's marble as it rolled from Z to H. [1]

- (c) State the furthest point Keith's and Frank's marbles could reach. Explain your answer. [2]
